

RPL201(H)/251/301

2000/2500/3000kg

Heavy-duty Pallet Truck



- Heavy duty truck with foldable platform and safety arms
- Powerful AC vertical traction motor
- Precise power steering with proportional effort
- Automatic speed reduction on turns
- High travelling speed and gradeability



Manufacturer			EP	EP	EP	EP
Model designation			RPL201	RPL201(H)	RPL251	RPL301
Drive			Electric	Electric	Electric	Electric
Load capacity	Q	kg	2000	2000	2500	3000
Load center distance	c	mm	600	600	600	600
Service weight		kg	670	670	802	802
Length to face of forks	l2	mm	804	804	824	824
Overall width		b1/b2	734	734	734	734
Fork dimensions	s/e/l	mm	55/170/1220	55/170/1220	55/190/1150	55/190/1150
Turning radius		Wa	1806	1806	1790	1790
Max. gradeability, laden/unladen		%	8/16	8/16	6/16	6/16
Travel speed, laden/unladen		km/ h	7.5/8	9/12	5.5/6	5.5/6
Battery voltage/nominal capacity		V/Ah	24/205	24/205	24/205	24/205

FEATURE

■ Lithium-ion technology

The RPL series is equipped with 24V/210Ah EP Li-ion battery that supports opportunity charging. Operators can charge the truck at preferable time during the day without disrupting working schedules.



■ Robust safety arms

The safety arms of the RPL series are produced from strengthened steel to ensure a long lifetime of the trucks structure.



■ More precise working mechanism

Using slider motion structure and one-time full-axis processing technology to ensure higher working accuracy.



■ Increase lifetime of movable parts

Adopting special pin material, heat treatment process and customized sleeve to make key movable parts more durable.



■ Strengthened loading wheel assembly

RPL251 and RPL301 come with strengthened frames and updated links of the loading wheels to improve wear resistance and meet heavy duty applications.



Electric Pallet Truck 2.0T

RPL201

	Item No.	Description	Unit	RPL201(Li)		
				EP	EP	
Distinguishing mark	1.1	Manufacturer		EP	EP	
	1.2	Model designation		RPL201(Li)	RPL201(Li)	
	1.3	Drive		Electric	Electric	
	1.4	Operator type		Standing	Standing	
	1.5	Load capacity	Q	kg	2000	2000
	1.6	Load center distance	c	mm	600	600
	1.8	Load distance, centre of drive axle to fork	x	mm	980	1000
	1.9	Wheelbase	y	mm	1531	1551
	Service weight	2.1	Service weight		kg	670
2.2		Axle loading, laden front/rear		kg	1060 / 1610	1060 / 1610
2.3		Axle loading, unladen front/rear		kg	540 / 130	540 / 130
Tyres/chassis	3.1	Tyre type			Polyurethane	Polyurethane
	3.2.1	Tyre size, front		mm	Φ230x75	Φ230x75
	3.3.1	Tyre size, rear		mm	Φ85x70/Φ83x115	Φ85x70/Φ83x115
	3.4	Additional wheels (castor wheels)		mm	Φ130x55	Φ130x55
	3.5	Wheels, number front/rear (x=drive wheels)		mm	1x+2/4/1x+2/2	1x+2/4/1x+2/2
	3.6.1	Tread width, front	b10	mm	510	510
	3.7.1	Tread width, rear	b11	mm	370 / 515	370 / 515
Dimensions	4.4	Lift height	h3	mm	120	120
	4.9	Height of tiller handle in drive position min./max.	h14	mm	1075 / 1288	1075 / 1288
	4.15	Lowered height	h13	mm	85	85
	4.19	Overall length	l1	mm	1954	2024
	4.20	Length to face of forks	l2	mm	804	804
	4.21	Overall width	b1/b2	mm	734	734
	4.22	Fork dimensions	s/e/l	mm	55 x 170 x 1150	55 x 170 x 1220
	4.25	Distance between fork-arms	b5	mm	540 / 685	540 / 685
	4.32	Ground clearance, center of wheelbase	m2	mm	30	30
	4.34.1	Aisle width for pallets 1000x1200 crossways	Ast	mm	2606	2606
	4.34.2	Aisle width for pallets 800x1200 crossways	Ast	mm	2463	2463
4.35	Turning radius	Wa	mm	1806	1826	
Performance data	5.1	Travel speed, laden/unladen		km/ h	7.5 / 8	7.5 / 8
	5.2	Lifting speed, laden/unladen		m/s	0.050 / 0.054	0.050 / 0.054
	5.3	Lowering speed, laden/unladen		m/s	0.067 / 0.054	0.067 / 0.054
	5.8	Max. gradeability, laden/unladen		%	8 / 16	8 / 16
	5.10	Service brake			Electromagnetic	Electromagnetic
Electric-engine	6.1	Drive motor rating S2 60 min		kW	1.6	1.6
	6.2	Lift motor rating at S3 15%		kW	2.2	2.2
	6.4	Battery voltage/nominal capacity		V/Ah	24 / 205AH	24 / 205AH
	6.5	Battery weight		kg	62	62
	Addition data	8.1	Type of drive control			AC
10.5		Steering design			Electronic	Electronic
10.7		Sound pressure level at the driver's ear		dB(A)	74	74

If there are improvements of technical parameters or configurations, no further notice will be given.
The diagram shown may contain non-standard configurations.

Electric Pallet Truck 2.0T

RPL201

				Distinguishing mark		
				EP	EP	
Distinguishing mark	1.1	Manufacturer			EP	EP
	1.2	Model designation			RPL201(Lead-acid)	RPL201(Lead-acid)
	1.3	Drive			Electric	Electric
	1.4	Operator type			Standing	Standing
	1.5	Load capacity	Q	kg	2000	2000
	1.6	Load center distance	c	mm	600	600
	1.8	Load distance, centre of drive axle to fork	x	mm	980	1000
	1.9	Wheelbase	y	mm	1531	1551
Service weight	2.1	Service weight			755	755
	2.2	Axle loading, laden front/rear			1090 / 1665	1090 / 1665
	2.3	Axle loading, unladen front/rear			600 / 155	600 / 155
Tyres/chassis	3.1	Tyre type			Polyurethane	Polyurethane
	3.2.1	Tyre size, front		mm	Φ230x75	Φ230x75
	3.3.1	Tyre size, rear		mm	Φ85x70/Φ83x115	Φ85x70/Φ83x115
	3.4	Additional wheels (castor wheels)		mm	Φ130x55	Φ130x55
	3.5	Wheels, number front/rear (x=drive wheels)		mm	1x+2/4/1x+2/2	1x+2/4/1x+2/2
	3.6.1	Tread width, front	b10	mm	510	510
	3.7.1	Tread width, rear	b11	mm	370 / 515	370 / 515
Dimensions	4.4	Lift height	h3	mm	120	120
	4.9	Height of tiller handle in drive position min./max.	h14	mm	1075 / 1288	1075 / 1288
	4.15	Lowered height	h13	mm	85	85
	4.19	Overall length	l1	mm	1954	2024
	4.20	Length to face of forks	l2	mm	804	804
	4.21	Overall width	b1/b2	mm	734	734
	4.22	Fork dimensions	s/e/l	mm	55 x 170 x 1150	55 x 170 x 1220
	4.25	Distance between fork-arms	b5	mm	540 / 685	540 / 685
	4.32	Ground clearance, center of wheelbase	m2	mm	30	30
	4.34.1	Aisle width for pallets 1000×1200 crossways	Ast	mm	2606	2606
	4.34.2	Aisle width for pallets 800×1200 crossways	Ast	mm	2463	2463
	4.35	Turning radius	Wa	mm	1806	1826
	Performance data	5.1	Travel speed, laden/unladen		km/ h	7.5 / 8
5.2		Lifting speed, laden/unladen		m/s	0.050 / 0.054	0.050 / 0.054
5.3		Lowering speed, laden/unladen		m/s	0.067 / 0.054	0.067 / 0.054
5.8		Max. gradeability, laden/unladen		%	8 / 16	8 / 16
5.10		Service brake			Electromagnetic	Electromagnetic
Electric-engine	6.1	Drive motor rating S2 60 min		kW	1.6	1.6
	6.2	Lift motor rating at S3 15%		kW	2.2	2.2
	6.4	Battery voltage/nominal capacity		V/Ah	24 / 280AH	24 / 280AH
	6.5	Battery weight		kg	255	255
	Addition data	8.1	Type of drive control			AC
10.5		Steering design			Electronic	Electronic
10.7		Sound pressure level at the driver's ear		dB(A)	74	74

If there are improvements of technical parameters or configurations, no further notice will be given. The diagram shown may contain non-standard configurations.

Electric Pallet Truck 2.0T

RPL201H

Distinguishing mark	1.1	Manufacturer			EP	EP
	1.2	Model designation			RPL201H(Li)	RPL201H(Li)
	1.3	Drive			Electric	Electric
	1.4	Operator type			Standing	Standing
	1.5	Load capacity	Q	kg	2000	2000
	1.6	Load center distance	c	mm	600	600
	1.8	Load distance, centre of drive axle to fork	x	mm	980	1000
	1.9	Wheelbase	y	mm	1531	1551
	Service weight	2.1	Service weight		kg	670
2.2		Axle loading, laden front/rear		kg	1060 / 1610	1060 / 1610
2.3		Axle loading, unladen front/rear		kg	540 / 130	540 / 130
Tyres/chassis	3.1	Tyre type			Polyurethane	Polyurethane
	3.2.1	Tyre size, front		mm	Φ230x75	Φ230x75
	3.3.1	Tyre size, rear		mm	Φ85x70/Φ83x115	Φ85x70/Φ83x115
	3.4	Additional wheels (castor wheels)		mm	Φ130x55	Φ130x55
	3.5	Wheels, number front/rear (x=drive wheels)		mm	1x+2/4/1x+2/2	1x+2/4/1x+2/2
	3.6.1	Tread width, front	b10	mm	510	510
	3.7.1	Tread width, rear	b11	mm	370 / 515	370 / 515
Dimensions	4.4	Lift height	h3	mm	120	120
	4.9	Height of tiller handle in drive position min./max.	h14	mm	1075 / 1288	1075 / 1288
	4.15	Lowered height	h13	mm	85	85
	4.19	Overall length	l1	mm	1954	2024
	4.20	Length to face of forks	l2	mm	804	804
	4.21	Overall width	b1/b2	mm	734	734
	4.22	Fork dimensions	s/e/l	mm	55 x 170 x 1150	55 x 170 x 1220
	4.25	Distance between fork-arms	b5	mm	540 / 685	540 / 685
	4.32	Ground clearance, center of wheelbase	m2	mm	30	30
	4.34.1	Aisle width for pallets 1000x1200 crossways	Ast	mm	2606	2606
	4.34.2	Aisle width for pallets 800x1200 crossways	Ast	mm	2463	2463
4.35	Turning radius	Wa	mm	1806	1826	
Performance data	5.1	Travel speed, laden/unladen		km/ h	9 / 12	9 / 12
	5.2	Lifting speed, laden/unladen		m/s	0.050 / 0.054	0.050 / 0.054
	5.3	Lowering speed, laden/unladen		m/s	0.067 / 0.054	0.067 / 0.054
	5.8	Max. gradeability, laden/unladen		%	8 / 16	8 / 16
	5.10	Service brake			Electromagnetic	Electromagnetic
Electric-engine	6.1	Drive motor rating S2 60 min		kW	2.5	2.5
	6.2	Lift motor rating at S3 15%		kW	2.2	2.2
	6.4	Battery voltage/nominal capacity		V/Ah	24 / 205AH	24 / 205AH
	6.5	Battery weight		kg	62	62
Addition data	8.1	Type of drive control			AC	AC
	10.5	Steering design			Electronic	Electronic
	10.7	Sound pressure level at the driver's ear		dB(A)	74	74

If there are improvements of technical parameters or configurations, no further notice will be given.
The diagram shown may contain non-standard configurations.

Electric Pallet Truck 2.0T

RPL201H

1.1	Manufacturer			EP	EP
1.2	Model designation			RPL201H(Lead-acid)	RPL201H(Lead-acid)
1.3	Drive			Electric	Electric
1.4	Operator type			Standing	Standing
1.5	Load capacity	Q	kg	2000	2000
1.6	Load center distance	c	mm	600	600
1.8	Load distance, centre of drive axle to fork	x	mm	980	1000
1.9	Wheelbase	y	mm	1531	1551
2.1	Service weight		kg	755	755
2.2	Axle loading, laden front/rear		kg	1090 / 1665	1090 / 1665
2.3	Axle loading, unladen front/rear		kg	600 / 155	600 / 155
3.1	Tyre type			Polyurethane	Polyurethane
3.2.1	Tyre size, front		mm	Φ230x75	Φ230x75
3.3.1	Tyre size, rear		mm	Φ85x70/Φ83x115	Φ85x70/Φ83x115
3.4	Additional wheels (castor wheels)		mm	Φ130x55	Φ130x55
3.5	Wheels, number front/rear (x=drive wheels)		mm	1x+2/4/1x+2/2	1x+2/4/1x+2/2
3.6.1	Tread width, front	b10	mm	510	510
3.7.1	Tread width, rear	b11	mm	370 / 515	370 / 515
4.4	Lift height	h3	mm	120	120
4.9	Height of tiller handle in drive position min./max.	h14	mm	1075 / 1288	1075 / 1288
4.15	Lowered height	h13	mm	85	85
4.19	Overall length	l1	mm	1954	2024
4.20	Length to face of forks	l2	mm	804	804
4.21	Overall width	b1/b2	mm	734	734
4.22	Fork dimensions	s/e/l	mm	55 x 170 x 1150	55 x 170 x 1220
4.25	Distance between fork-arms	b5	mm	540 / 685	540 / 685
4.32	Ground clearance, center of wheelbase	m2	mm	30	30
4.34.1	Aisle width for pallets 1000×1200 crossways	Ast	mm	2606	2606
4.34.2	Aisle width for pallets 800×1200 crossways	Ast	mm	2463	2463
4.35	Turning radius	Wa	mm	1806	1826
5.1	Travel speed, laden/unladen		km/ h	9 / 12	9 / 12
5.2	Lifting speed, laden/unladen		m/s	0.050 / 0.054	0.050 / 0.054
5.3	Lowering speed, laden/unladen		m/s	0.067 / 0.054	0.067 / 0.054
5.8	Max. gradeability, laden/unladen		%	8 / 16	8 / 16
5.10	Service brake			Electromagnetic	Electromagnetic
6.1	Drive motor rating S2 60 min		kW	2.5	2.5
6.2	Lift motor rating at S3 15%		kW	2.2	2.2
6.4	Battery voltage/nominal capacity		V/Ah	24 / 280AH	24 / 280AH
6.5	Battery weight		kg	255	255
8.1	Type of drive control			AC	AC
10.5	Steering design			Electronic	Electronic
10.7	Sound pressure level at the driver's ear		dB(A)	74	74

If there are improvements of technical parameters or configurations, no further notice will be given.
The diagram shown may contain non-standard configurations.

Electric Pallet Truck 2.5T

RPL251

Distinguishing mark	1.1	Manufacturer			EP	EP
	1.2	Model designation			RPL251(Li)	RPL251(Lead-acid)
	1.3	Drive			Electric	Electric
	1.4	Operator type			Standing	Standing
	1.5	Load capacity	Q	kg	2500	2500
	1.6	Load center distance	c	mm	600	600
	1.8	Load distance, centre of drive axle to fork	x	mm	916	916
	1.9	Wheelbase	y	mm	1531	1531
	Service weight	2.1	Service weight		kg	802
2.2		Axle loading, laden front/rear		kg	1120 / 1670	1120 / 1670
2.3		Axle loading, unladen front/rear		kg	650 / 140	650 / 140
Tyres/chassis	3.1	Tyre type			Polyurethane	Polyurethane
	3.2.1	Tyre size, front		mm	Φ85x70 / Φ83x115	Φ85x70 / Φ83x115
	3.3.1	Tyre size, rear		mm	Φ230x75	Φ230x75
	3.4	Additional wheels (castor wheels)		mm	Φ130x55	Φ130x55
	3.5	Wheels, number front/rear (x=drive wheels)		mm	1 x +2/4 / 1 x + 2/2	1 x +2/4 / 1 x + 2/2
	3.6.1	Tread width, front	b10	mm	510	510
	3.7.1	Tread width, rear	b11	mm	370 / 495	370 / 495
Dimensions	4.4	Lift height	h3	mm	120	120
	4.9	Height of tiller handle in drive position min./max.	h14	mm	1075 / 1288	1075 / 1288
	4.15	Lowered height	h13	mm	85	85
	4.19	Overall length	l1	mm	1954	1954
	4.20	Length to face of forks	l2	mm	824	824
	4.21	Overall width	b1/b2	mm	734	734
	4.22	Fork dimensions	s/e/l	mm	55 x 190 x 1150	55 x 190 x 1150
	4.25	Distance between fork-arms	b5	mm	560 / 685	560 / 685
	4.32	Ground clearance, center of wheelbase	m2	mm	30	30
	4.34.1	Aisle width for pallets 1000x1200 crossways	Ast	mm	2590	2590
	4.34.2	Aisle width for pallets 800x1200 crossways	Ast	mm	2447	2447
4.35	Turning radius	Wa	mm	1790	1790	
Performance data	5.1	Travel speed, laden/unladen		km/ h	5.5 / 6	5.5 / 6
	5.2	Lifting speed, laden/unladen		m/s	0.050 / 0.054	0.050 / 0.054
	5.3	Lowering speed, laden/unladen		m/s	0.067 / 0.054	0.067 / 0.054
	5.8	Max. gradeability, laden/unladen		%	6 / 16	6 / 16
	5.10	Service brake			Electromagnetic	Electromagnetic
Electric-engine	6.1	Drive motor rating S2 60 min		kW	2.5	2.5
	6.2	Lift motor rating at S3 15%		kW	2.2	2.2
	6.4	Battery voltage/nominal capacity		V/Ah	24 / 205	24 / 280
	6.5	Battery weight		kg	62	255
	Addition data	8.1	Type of drive control			AC
10.5		Steering design			Electronic	Electronic
10.7		Sound pressure level at the driver's ear		dB(A)	74	74

If there are improvements of technical parameters or configurations, no further notice will be given. The diagram shown may contain non-standard configurations.

Electric Pallet Truck 3.0T

RPL301

Distinguishing mark	1.1	Manufacturer			EP	EP
	1.2	Model designation			RPL301(Li)	RPL301(Lead-acid)
	1.3	Drive			Electric	Electric
	1.4	Operator type			Standing	Standing
	1.5	Load capacity	Q	kg	3000	3000
	1.6	Load center distance	c	mm	600	600
	1.8	Load distance, centre of drive axle to fork	x	mm	916	916
	1.9	Wheelbase	y	mm	1531	1531
	Service weight	2.1	Service weight		kg	802
2.2		Axle loading, laden front/rear		kg	1370 / 2420	1370 / 2420
2.3		Axle loading, unladen front/rear		kg	650 / 140	650 / 140
Tyres/chassis	3.1	Tyre type			Polyurethane	Polyurethane
	3.2.1	Tyre size, front		mm	Φ85x70 / Φ83x115	Φ85x70 / Φ83x115
	3.3.1	Tyre size, rear		mm	Φ230x75	Φ230x75
	3.4	Additional wheels (castor wheels)		mm	Φ130x55	Φ130x55
	3.5	Wheels, number front/rear (x=drive wheels)		mm	1 x +2/4 / 1 x + 2/2	1 x +2/4 / 1 x + 2/2
	3.6.1	Tread width, front	b10	mm	510	510
	3.7.1	Tread width, rear	b11	mm	370 / 495	370 / 495
Dimensions	4.4	Lift height	h3	mm	120	120
	4.9	Height of tiller handle in drive position min./max.	h14	mm	1075 / 1288	1075 / 1288
	4.15	Lowered height	h13	mm	85	85
	4.19	Overall length	l1	mm	1954	1954
	4.20	Length to face of forks	l2	mm	824	824
	4.21	Overall width	b1/b2	mm	734	734
	4.22	Fork dimensions	s/e/l	mm	55 x 190 x 1150	55 x 190 x 1150
	4.25	Distance between fork-arms	b5	mm	560 / 685	560 / 685
	4.32	Ground clearance, center of wheelbase	m2	mm	30	30
	4.34.1	Aisle width for pallets 1000×1200 crossways	Ast	mm	2590	2590
	4.34.2	Aisle width for pallets 800×1200 crossways	Ast	mm	2447	2447
4.35	Turning radius	Wa	mm	1790	1790	
Performance data	5.1	Travel speed, laden/unladen		km/ h	5.5 / 6	5.5 / 6
	5.2	Lifting speed, laden/unladen		m/s	0.050 / 0.054	0.050 / 0.054
	5.3	Lowering speed, laden/unladen		m/s	0.067 / 0.054	0.067 / 0.054
	5.8	Max. gradeability, laden/unladen		%	6 / 16	6 / 16
	5.10	Service brake			Electromagnetic	Electromagnetic
Electric-engine	6.1	Drive motor rating S2 60 min		kW	2.5	2.5
	6.2	Lift motor rating at S3 15%		kW	2.2	2.2
	6.4	Battery voltage/nominal capacity		V/Ah	24 / 205	24 /280
	6.5	Battery weight		kg	62	255
	8.1	Type of drive control			AC	AC
Addition data	10.5	Steering design			Electronic	Electronic
	10.7	Sound pressure level at the driver's ear		dB(A)	74	74

If there are improvements of technical parameters or configurations, no further notice will be given.
The diagram shown may contain non-standard configurations.

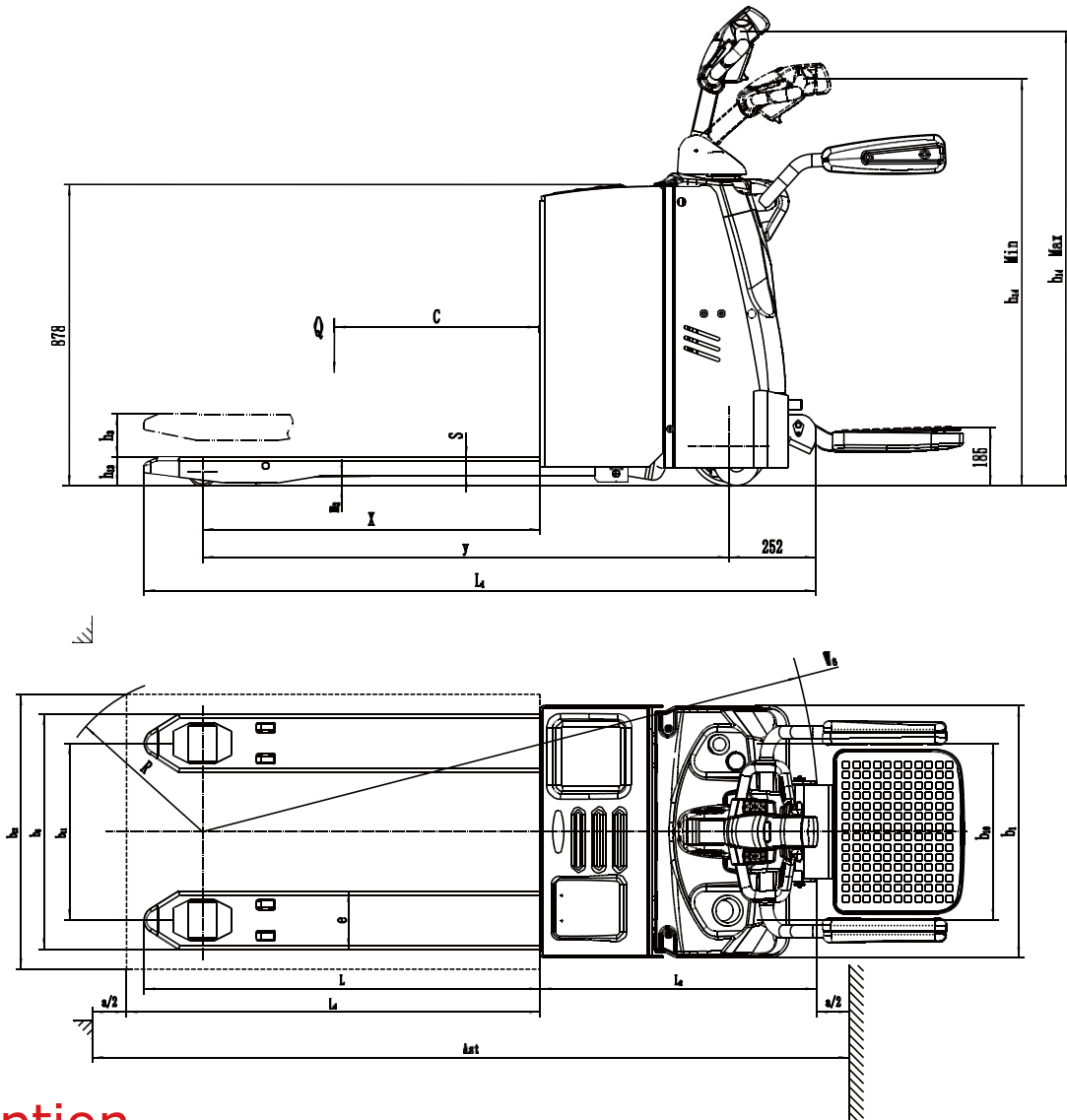

Option

No.	Optional items	RPL201/RPL201H
1.1	Fork length	●1150/1220○850/1000/1300/1450/1600/1800 /2000/2200/2400
1.2	Fork width	●540/685○600/725/790/840/940/1000 /1050/1100/1200
1.3	Fork lowered height	●85
1.4	Fork carriage width	●740
1.5	Fork carriage height	○1220mm (48in) ○1520mm (60in)
2.1	Load wheel type	●Double○Single
2.2	Load wheel material	●PU
2.3	Drive wheel material	●PU○Trace PU○Rubber
2.7	Battery capacity	●205Ah●210Ah (Lead Acid battery) ○280Ah/345Ah (Lead Acid battery)
2.8	Charger	●24V-100A External ●24V-30A External (Lead Acid battery) ○24V-50A External (Lead Acid battery)
2.9	Battery indicator	●Yueli Hourmeter (With time) ●Yaneng Hourmeter (With time) (Lead Acid battery)
3.3	Castor wheels	●Yes and not customized
3.4	Water auto-filling system	○Yes and not customized
4.1	Battery side pull function	○Yes and not customized
4.2	Cold storage	○Yes and not customized
4.4	Weighting system with fork	○Yes and not customized

Note: ●Standard ○Optional - Inconformity

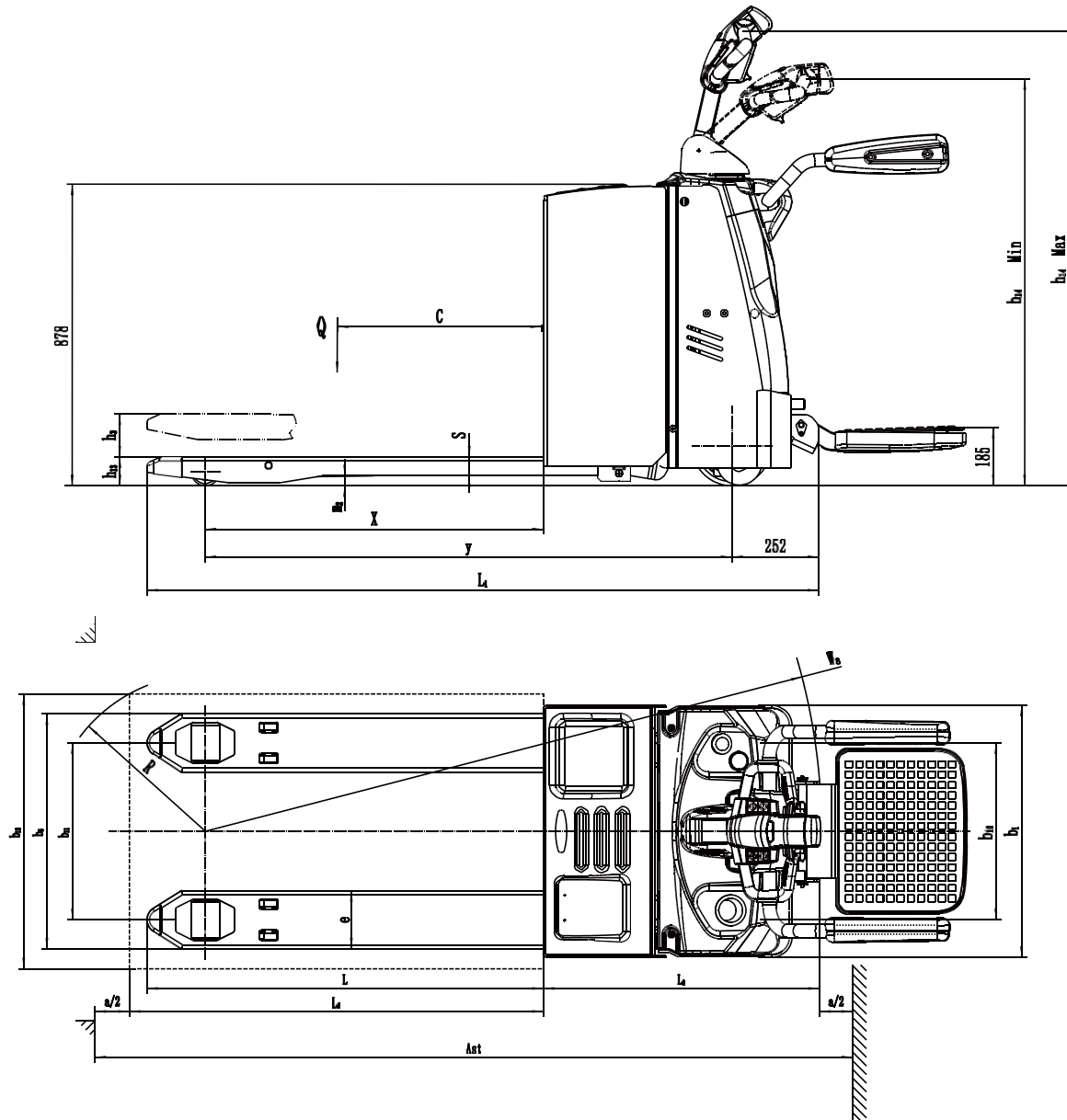

Option

No.	Optional items	RPL215/RPL301
1.1	Fork length	●1150/1220○850/1000/1300/1450/1600/1800 /2000/2200/2400
1.2	Fork width	●560/685○830/880/980/1040/1090/1140/1240
1.3	Fork lowered height	●85
1.4	Fork carriage width	750
1.5	Fork carriage height	○1220mm (48in) ○1520mm (60in)
2.1	Load wheel type	●Double○Single
2.2	Load wheel material	●PU
2.3	Drive wheel material	●PU○Trace PU○Rubber
2.7	Battery capacity	●205Ah (Li-Ion truck) ●280Ah (lead-acid truck) ○210Ah/345Ah (lead-acid truck)
2.8	Charger	●24V-100Aexternal charger (205Ah) ●24V-30Aexternal charger (210/280Ah) ○24V-50Aexternal charger (345Ah)
2.9	Battery indicator	●With time
3.3	Castor wheels	●Castor wheels
3.4	Water auto-filling system	○Water auto-filling system
4.1	Battery side pull function	○Battery side pull function (only for lead-acid truck)
Note: ●Standard ○Optional - Inconformity		

Load Capability Chart

Fork length (mm)	Load capacity (kg)		
	RPL201/RPL201H	RPL251	RPL301
850	2000KG	2500KG	3000KG
1000			
1150			
1220			
1300			
1450	1800KG		2700KG
1600			
1800			
2000	1600KG		2500KG
2200			
2400			

Application scenario

